

Modeling and Evaluating NFV-enabled Network Services under Different Availability Modes

Besmir Tola

besmir.tola@ntnu.no

Department of Information Security and
Communication Technology, NTNU-Norwegian
University of Science and Technology

Gianfranco Nencioni

gianfranco.nencioni@uis.no

Department of Electrical and Computer
Engineering, University of Stavanger

Bjarne E. Helvik, Yuming Jiang

{bjarne.e.helvik, yuming.jiang}@ntnu.no

Department of Information Security and
Communication Technology, NTNU-Norwegian
University of Science and Technology

Agenda

- NFV-enabled Network Service
 - Dependability Requirements
 - Dependability Challenges
 - Contribution
- Modeling Approach
 - Assumptions
 - Formalism
 - Composed Model
 - Availability Modes (AM)
- Numerical Evaluation
 - VNF redundancy configuration
 - Element dimensioning
 - Impact of cluster configuration
- Result Summary and Outlook for Future Work



NFV-enabled Network Service - Motivation

- Dependability Requirements and Challenges
 - Services with specific availability requirements
 - Various SAL (Service Availability Levels)
 - Telecom services have very stringent requirements (5-nines or more)
 - Virtualization layer decouples software from hardware (no control)
 - Complex architecture (M&O)
 - Extensive use of COTS hardware
- Prior studies on dependability modelling of NFV-enabled services
 - Stochastic Rewards Nets with limited failure sources
 - Stochastic Activity Networks specific to a single NFV use case (vEPC)
- Our Contribution
 - **Composed** model of an NFV service chain
 - Models for **different** Availability Modes
 - **Evaluate the** impact of different failure sources and redundancy configurations

Modelling Approach - Assumptions

- Network Service as Composable Stochastic Activity Networks

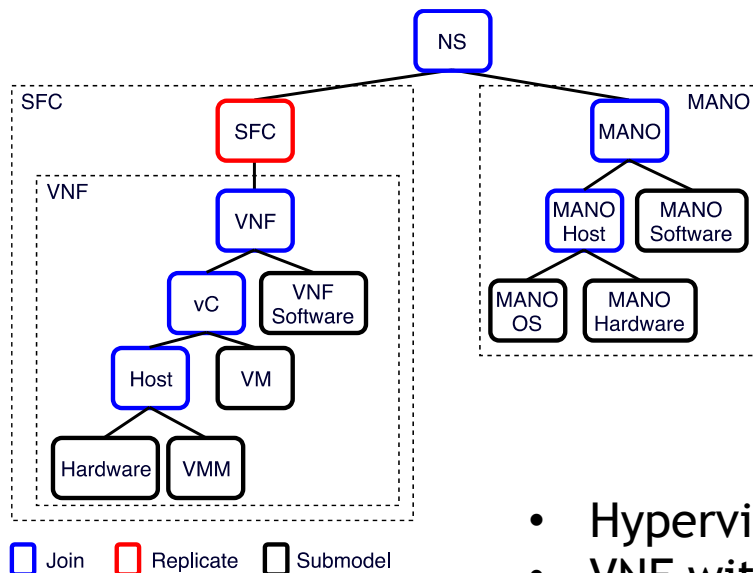

- Hypervisor-based on bare-metal virtualization
- VNF with a dedicated VM
- Each VNF fails independently
- Non-virtualized MANO*

* <https://openbaton.github.io/>

Modelling Approach – Composed Model

- Network Service as Composable Stochastic Activity Networks

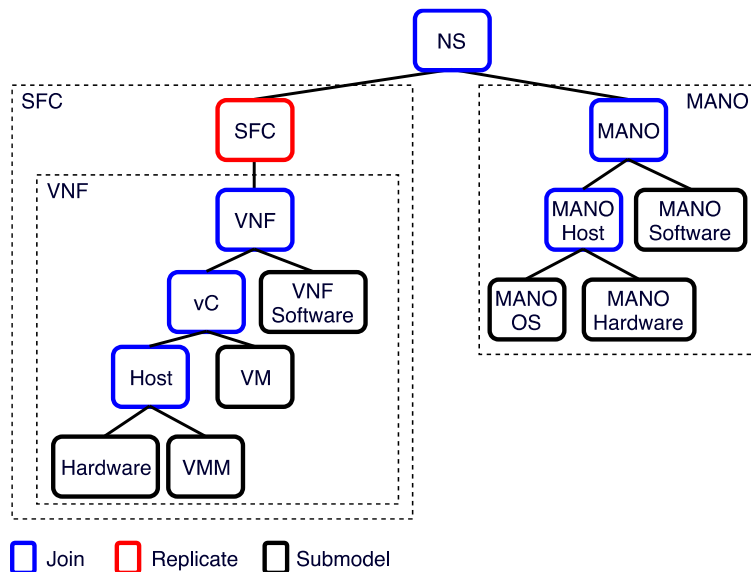

Modelling Approach – Composed Model

- Network Service as Composable Stochastic Activity Networks

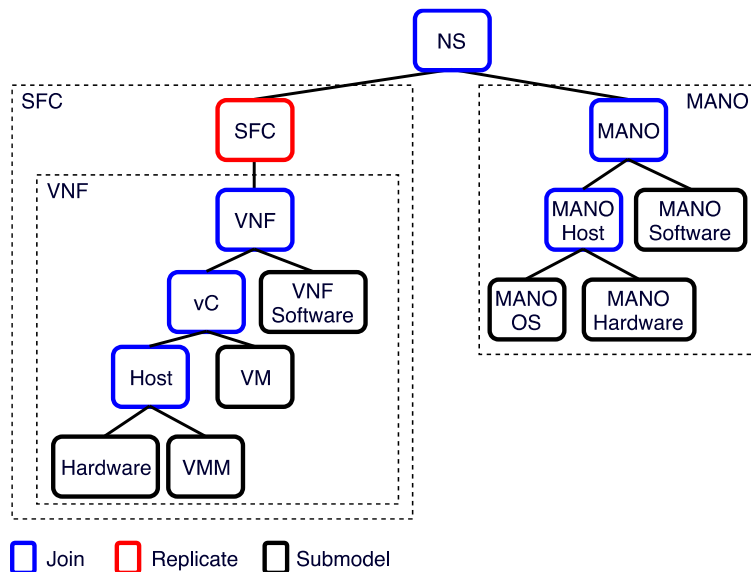

Join Node: state-sharing node joining two or more atomic submodels or other Join nodes.

Modelling Approach – Composed Model

- Network Service as Composable Stochastic Activity Networks

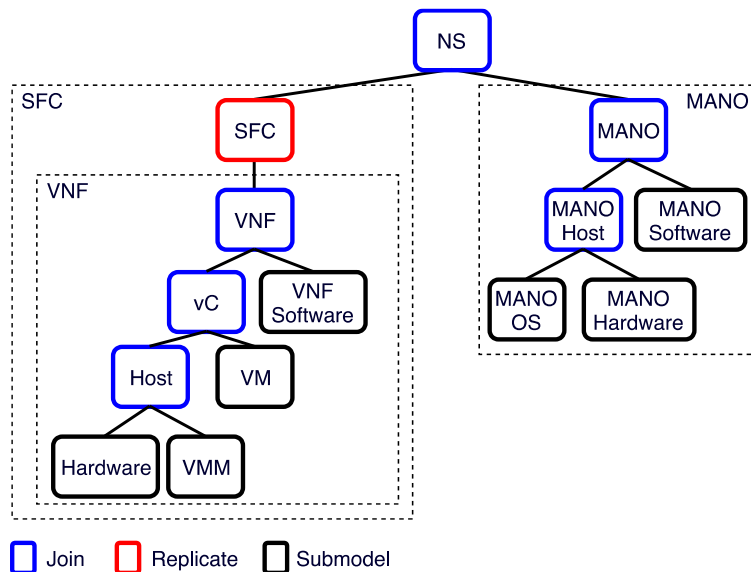

- Join Node: state-sharing node joining two or more atomic submodels or other Join nodes.
- Replicate Node: Special Join node that replicates its child nodes

Modelling Approach – Composed Model

- Network Service as Composable Stochastic Activity Networks

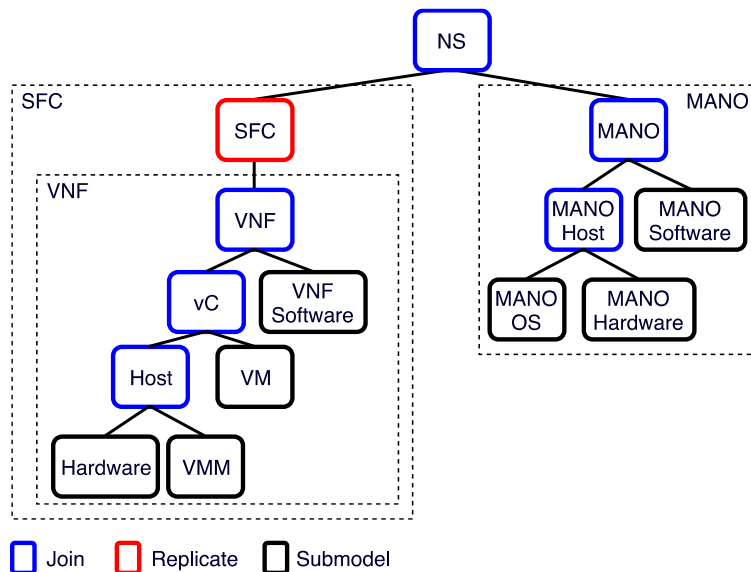

- Join Node: state-sharing node joining two or more atomic submodels or other Join nodes.
- Replicate Node: Special Join node that replicates its child nodes
- Atomic submodel representing a specific service component (SAN model)

Modelling Approach – Composed Model

- Network Service as Composable Stochastic Activity Network (SAN)

<https://www.mobius.illinois.edu/>

Modelling Approach – Composed Model

- Network Service as Composable Stochastic Activity Network (SAN)

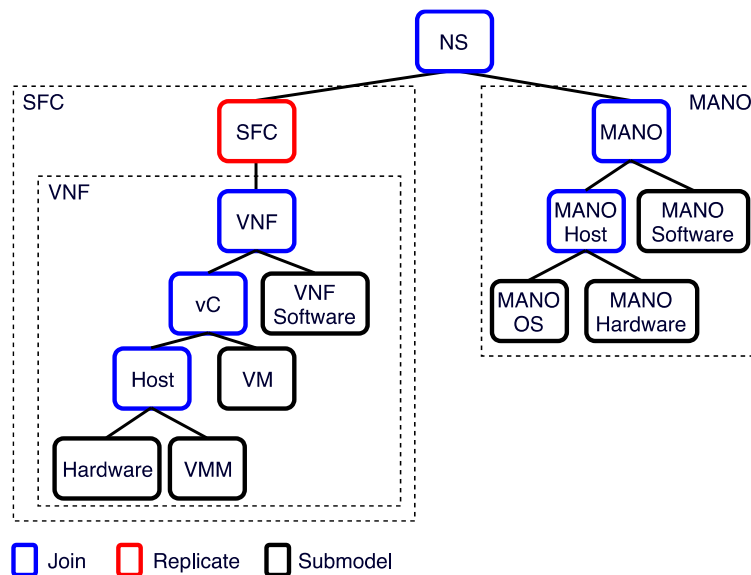

<https://www.mobius.illinois.edu/>

Modelling Approach – Composed Model

- Network Service as Composable Stochastic Activity Network (SAN)

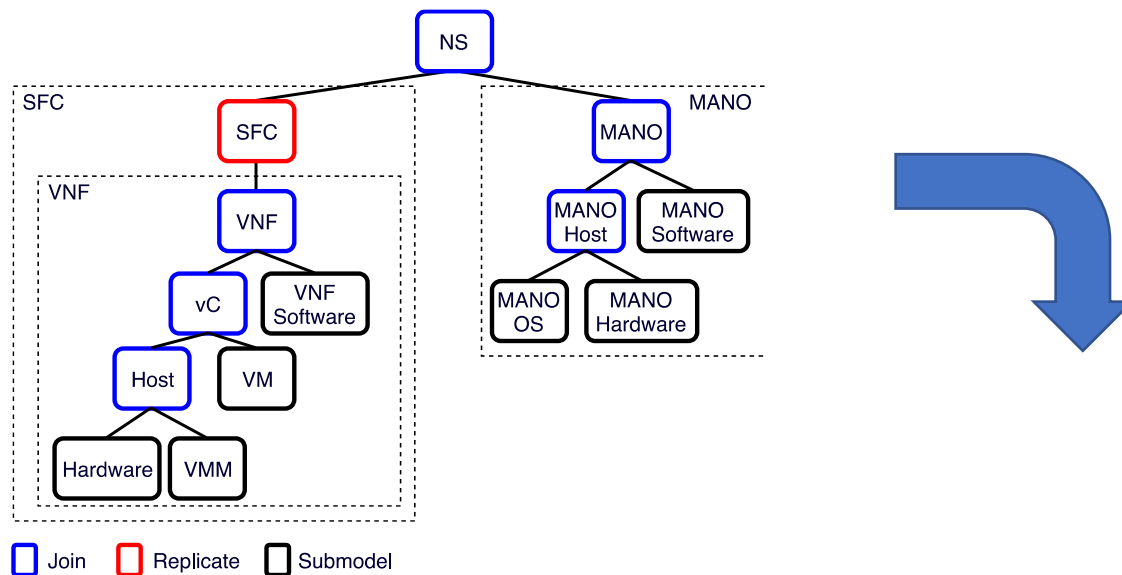

<https://www.mobius.illinois.edu/>

Modelling Approach – Composed Model

- Network Service as Composable Stochastic Activity Network (SAN)

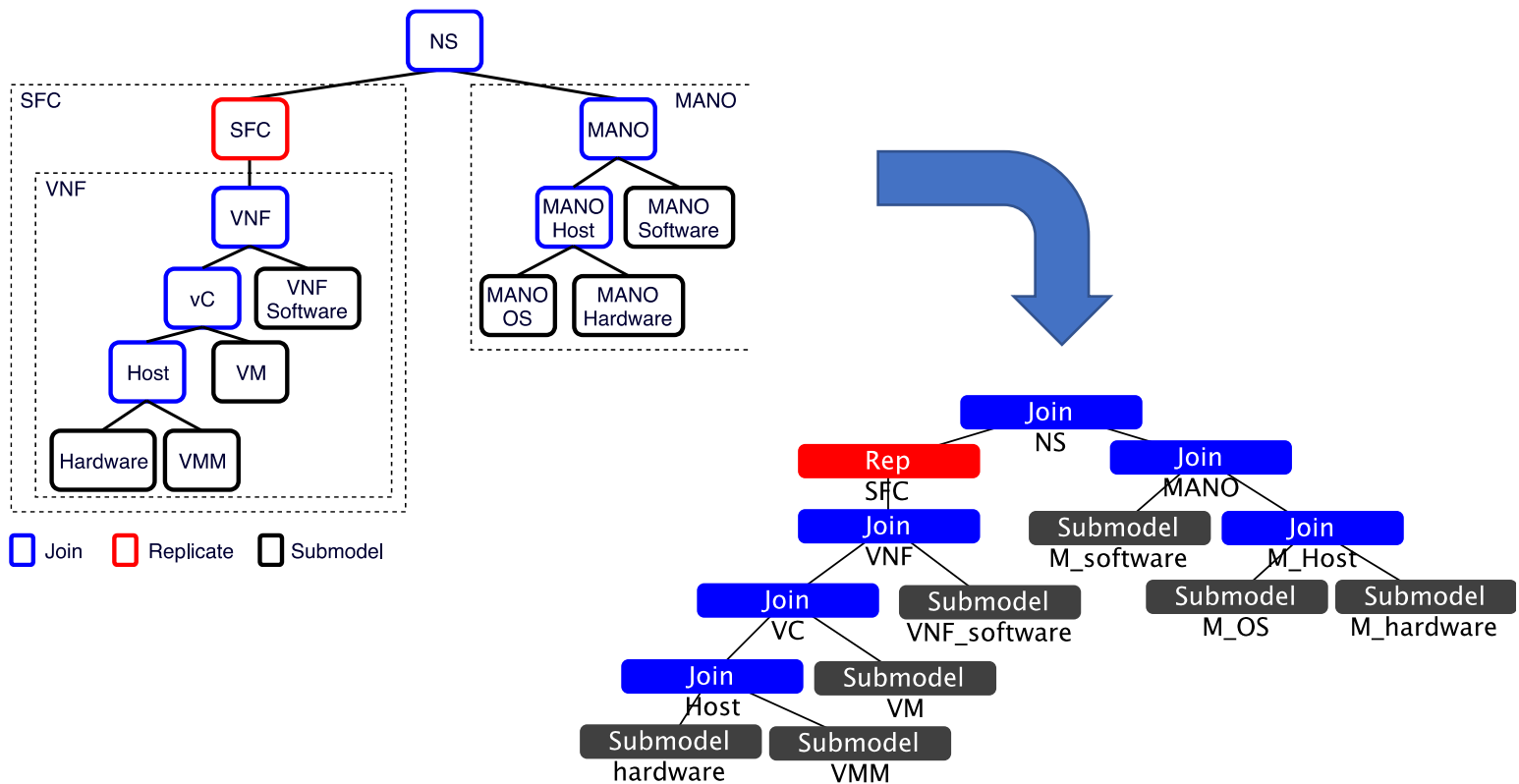

<https://www.mobius.illinois.edu/>

Modelling Approach – Composed Model

- Network Service as Composable Stochastic Activity Network (SAN)

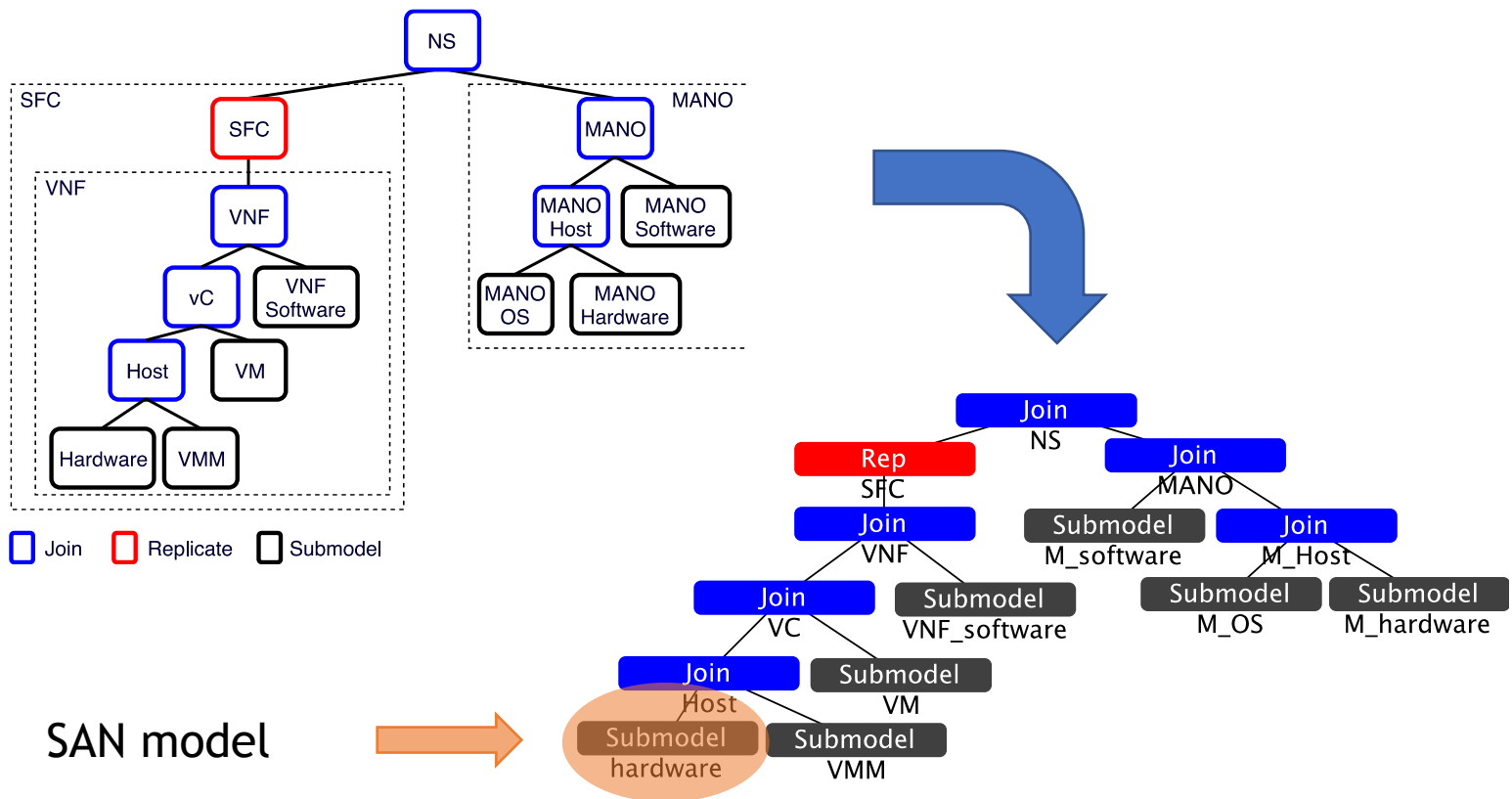

<https://www.mobius.illinois.edu/>

Modelling Approach – SAN Formalism

- SAN primitives

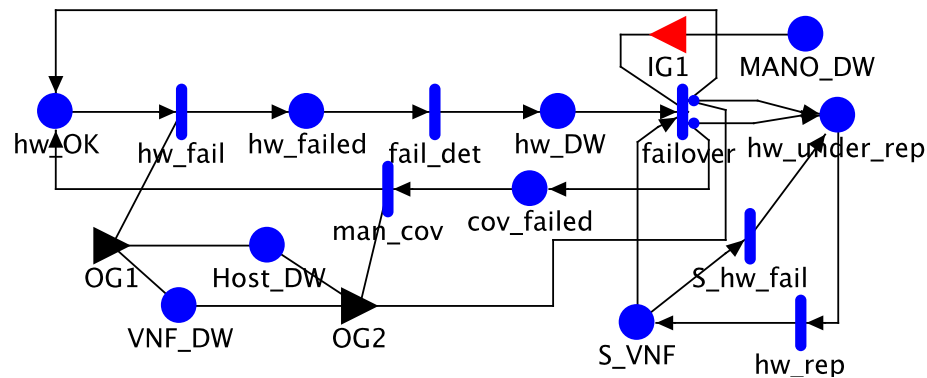

<https://www.mobius.illinois.edu/>

Modelling Approach – SAN Formalism

- SAN primitives

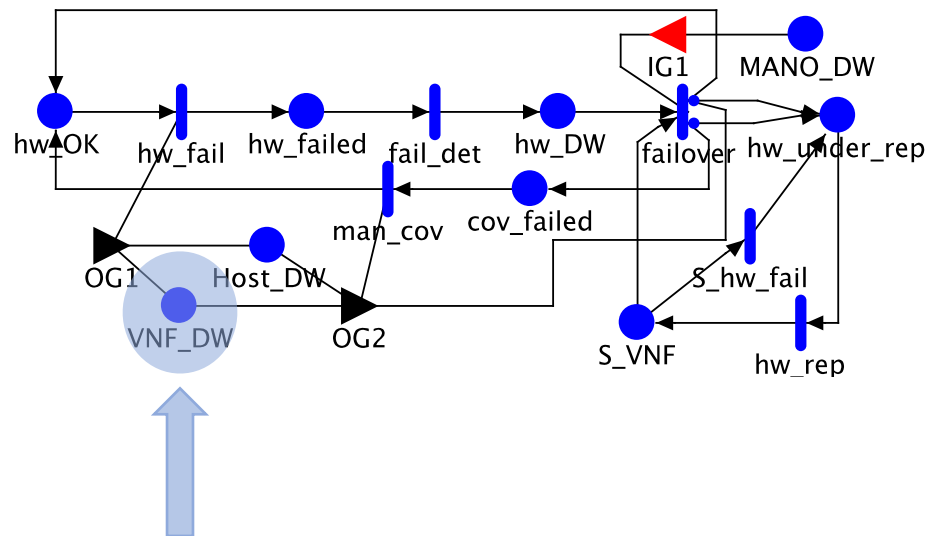

PLACE

Contain tokens (markings) where combinations of markings in all places define a system state

<https://www.mobius.illinois.edu/>

Modelling Approach – SAN Formalism

- SAN primitives

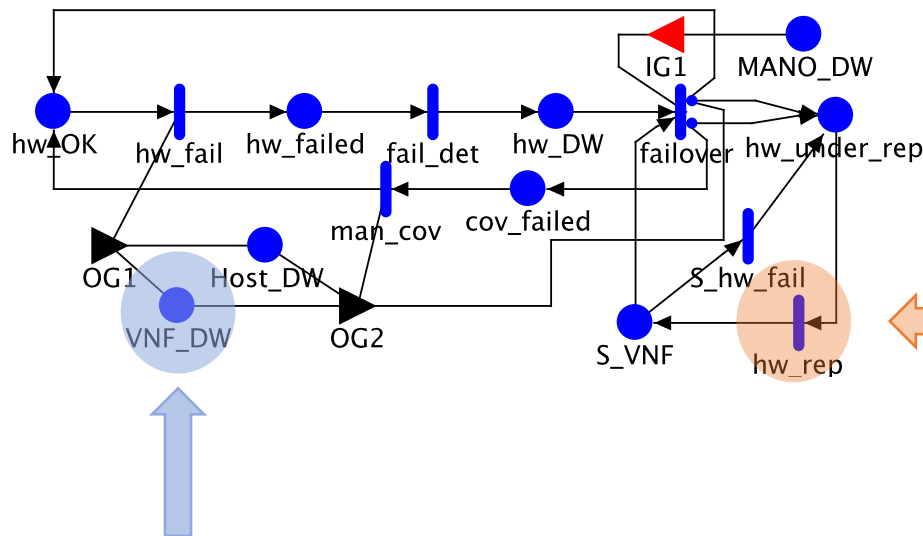

PLACE

Contain tokens (markings) where combinations of markings in all places define a system state

Activity

Change a system state upon firing which can be deterministic or following a specific distribution

<https://www.mobius.illinois.edu/>

Modelling Approach – SAN Formalism

- SAN primitives

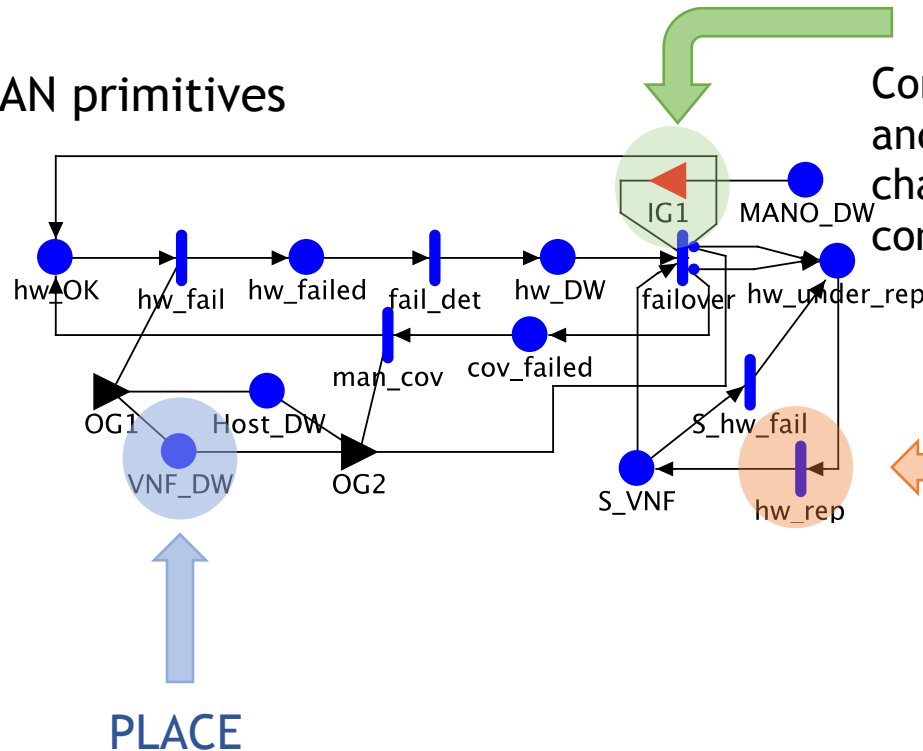

Input Gate
Control the activity firing and define the marking changes once the activity completes.

Activity
Change a system state upon firing which can be deterministic or following a specific distribution

PLACE
Contain tokens (markings) where combinations of markings in all places define a system state

<https://www.mobius.illinois.edu/>

Modelling Approach – SAN Formalism

- SAN primitives

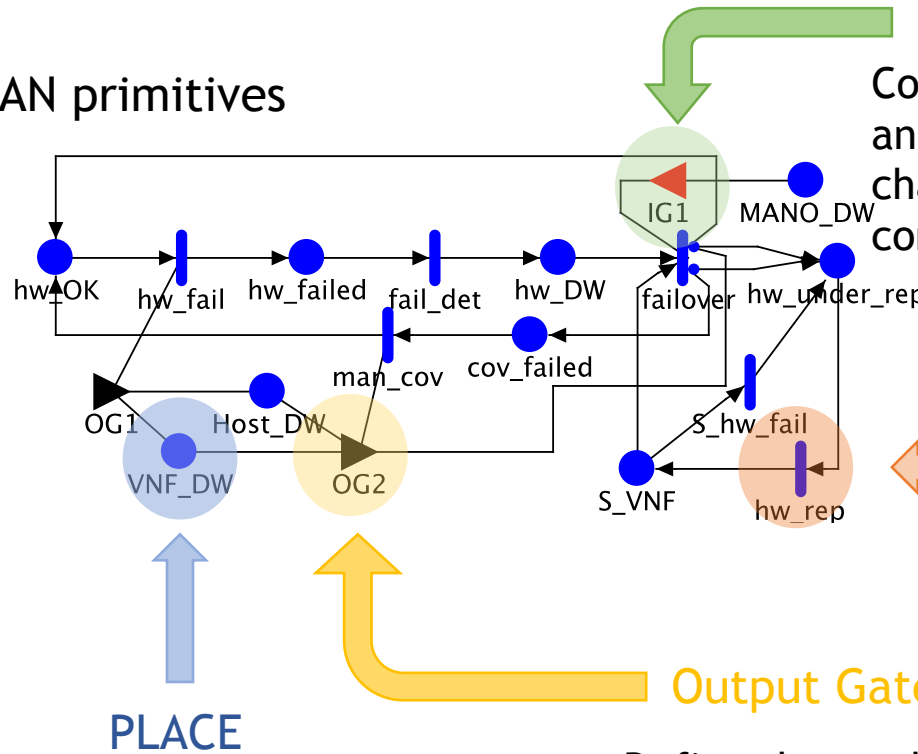

Input Gate
Control the activity firing and define the marking changes once the activity completes.

Activity
Change a system state upon firing which can be deterministic or following a specific distribution

Output Gate
Define the marking changes that will occur when activities complete but only for one case

PLACE

Contain tokens (markings) where combinations of markings in all places define a system state

<https://www.mobius.illinois.edu/>

Modelling Approach – SFC configuration

- Service chain composed of three services (VNFs)
- Each service as a VNF load-sharing cluster with K units
- The service is operational if at least N out of K VNF units are up
- Overprovisioning ratio*
- Redundancy provided with additional M units
- MANO with *overprovisioning ratio*

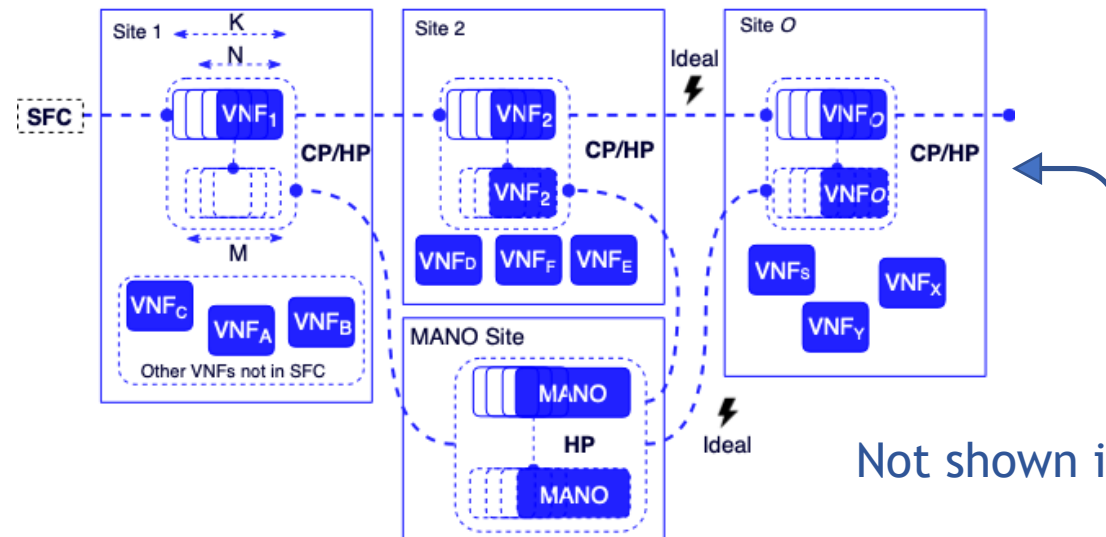

Modelling Approach – Availability Modes

- Standard Availability (SA)
 - No redundancy
 - Hardware recovery requires manual repair
 - Software level recovery (VNF, VM or VMM) follows two step procedure
 - Automatic restart/reboot
 - Hard repair, i.e., software fixing/patching
- Cold Protection (CP)
 - Redundancy on the Host level (Primary <-> Secondary)
 - Heartbeat messages
 - Primary failure => migrate VMs to Secondary Host (automatic migration)
 - VM/VNF recovery follow two step procedure
 - Automatic restart/reboot on the primary Host
 - Hard repair, i.e., software fixing/patching
- Hot Protection (HP)
 - Redundancy on the VNF level (Primary <-> Secondary)
 - Heartbeat messages and logging traffic between Primary and Secondary
 - Primary failure on all levels => failover to secondary VNF (automatic failover)

Component's Models - I

SA

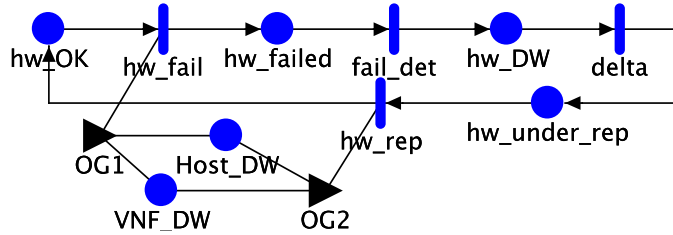

CP [HP]

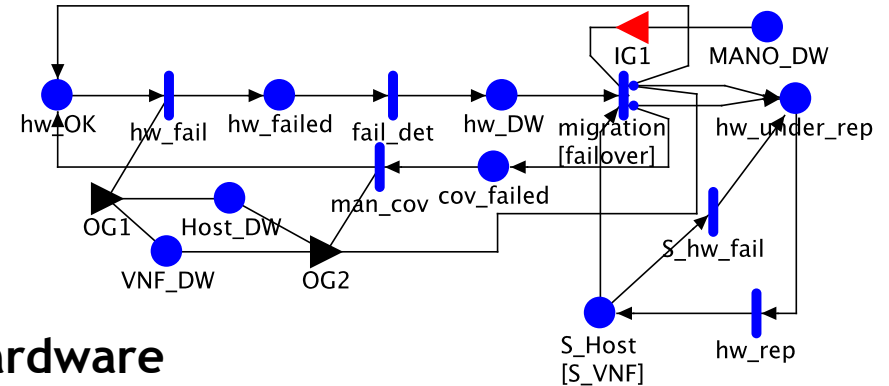

Hardware

SA

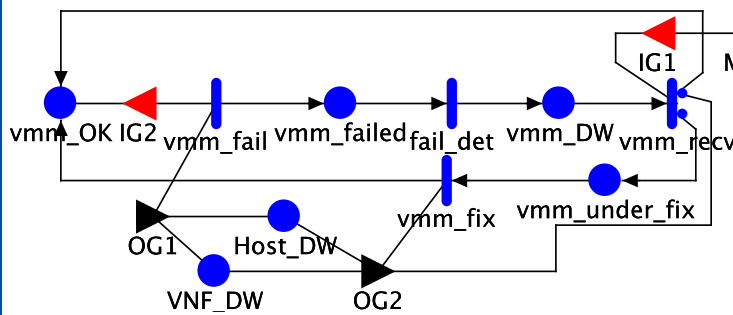

CP [HP]

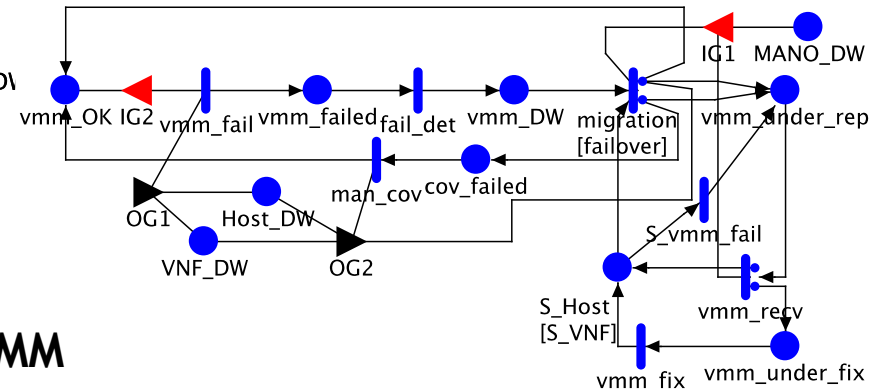

VMM

Component's Models - I

SA

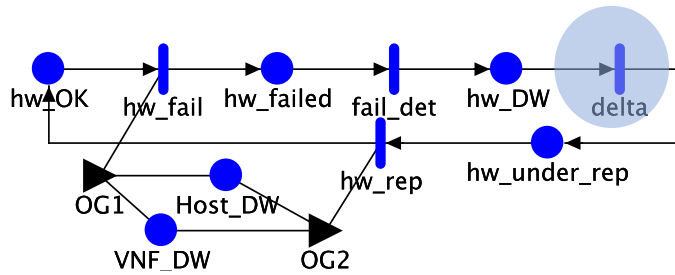

CP [HP]

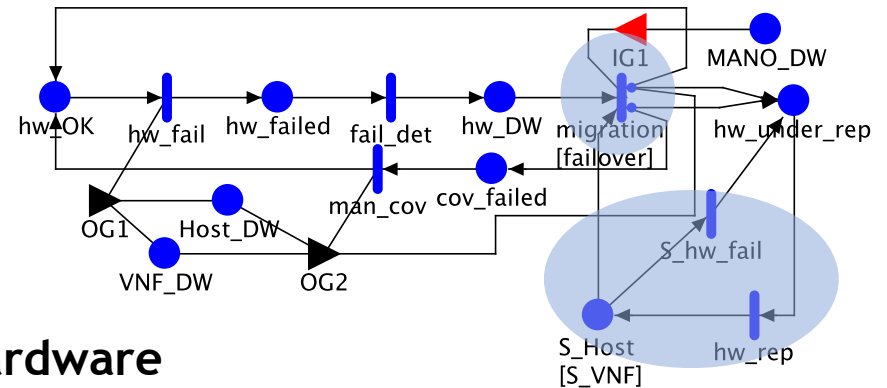

Hardware

SA

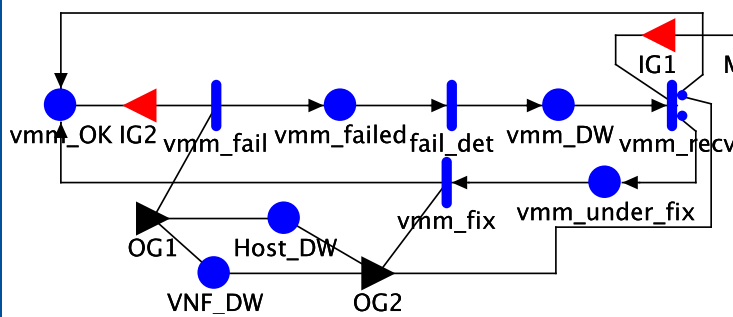

CP [HP]

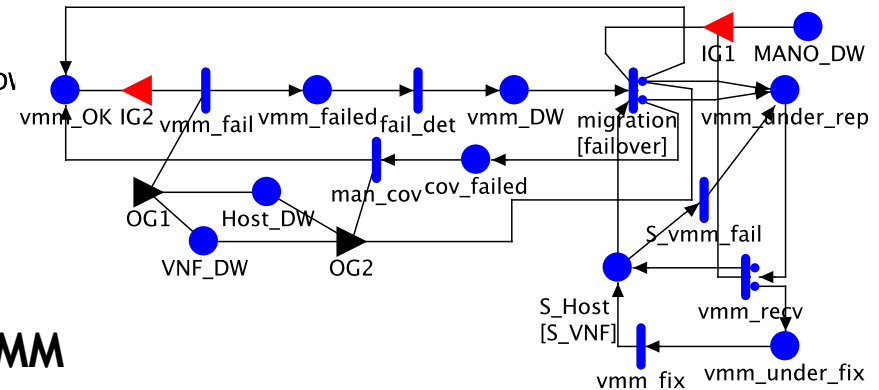

VMM

Component's Models - I

SA

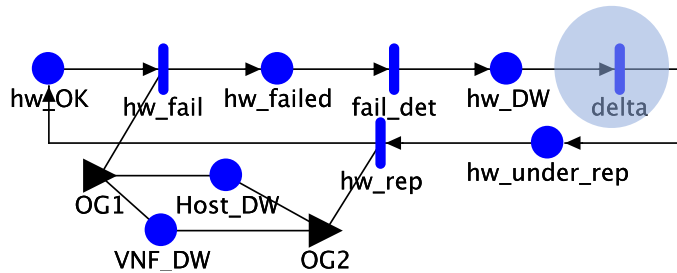

CP [HP]

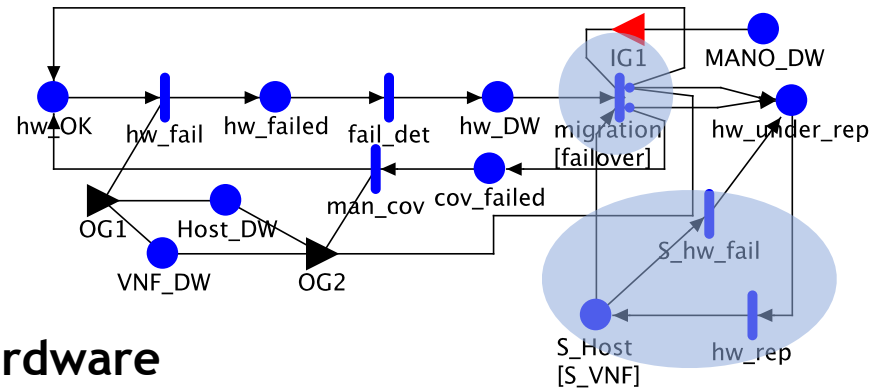

Hardware

SA

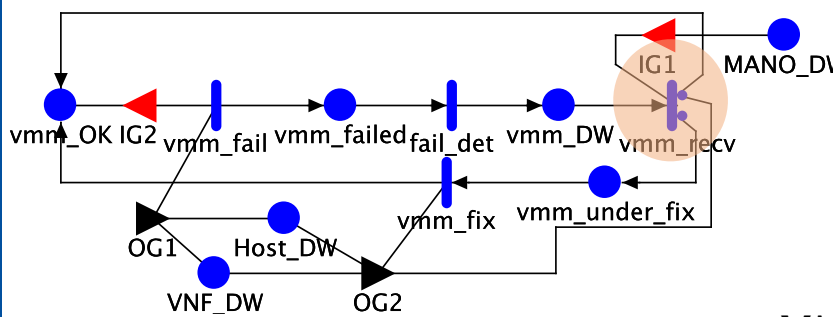

CP [HP]

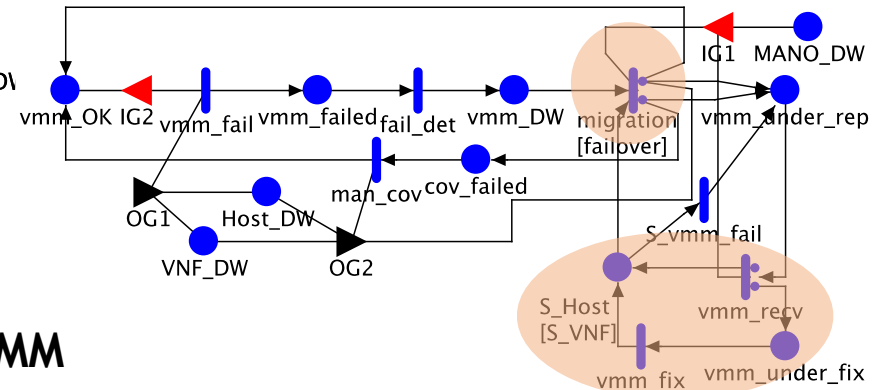

VMM

Component's Models - II

SA/CP

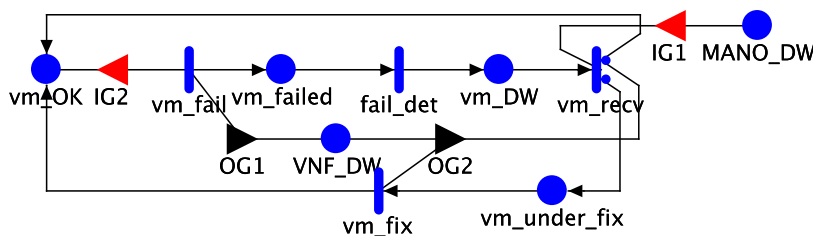

HP

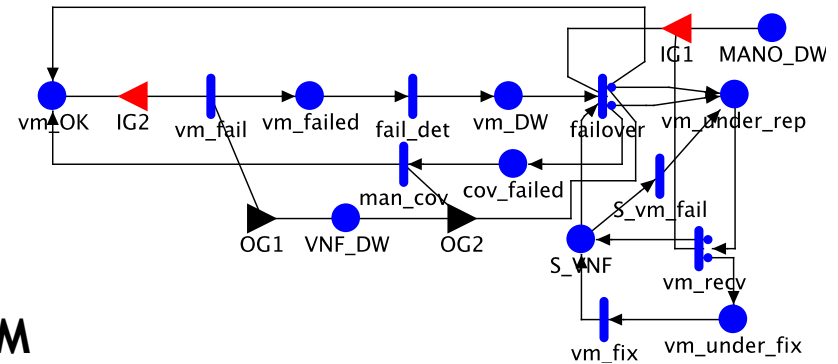

VM

SA/CP

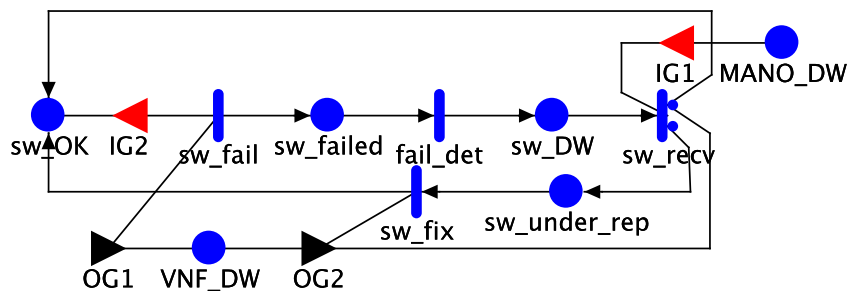

HP

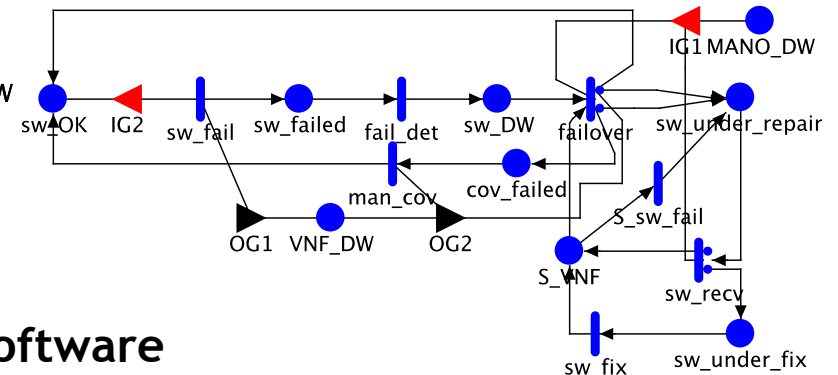

VNF Software

Component's Models - II

SA/CP

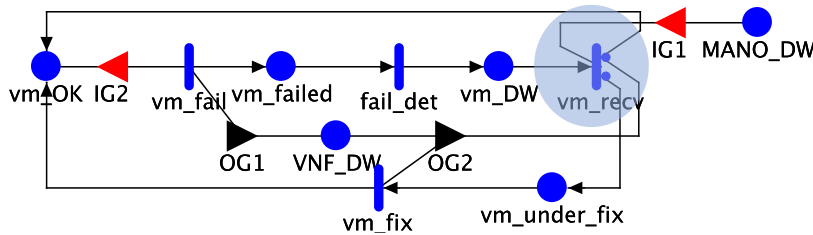

HP

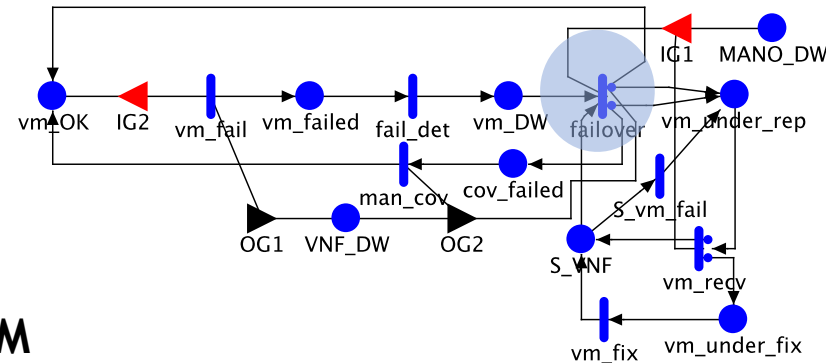

VM

SA/CP

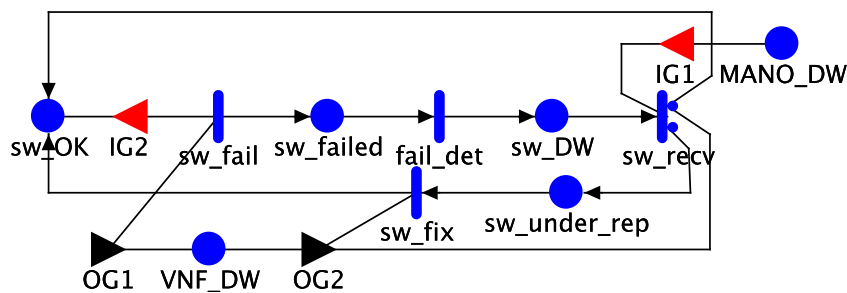

HP

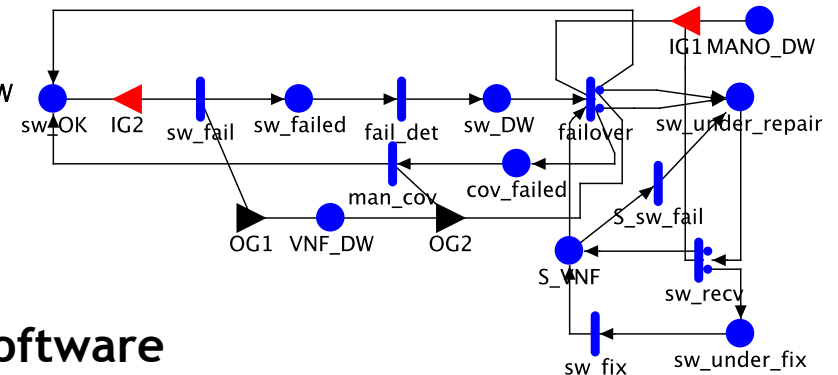

VNF Software

Component's Models - II

SA/CP

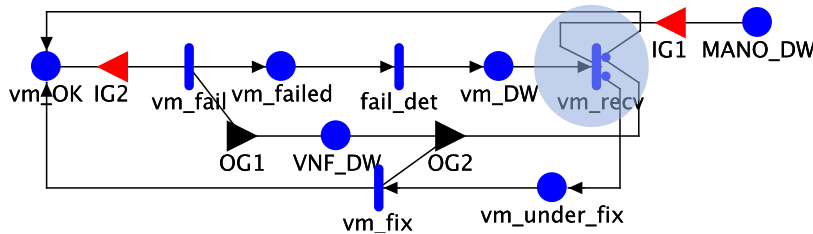

HP

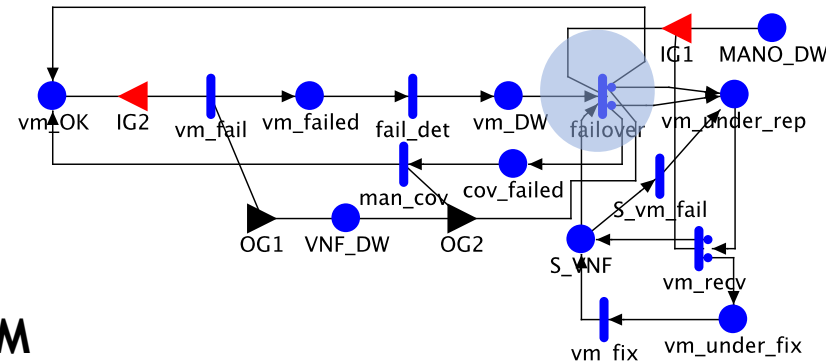

VM

SA/CP

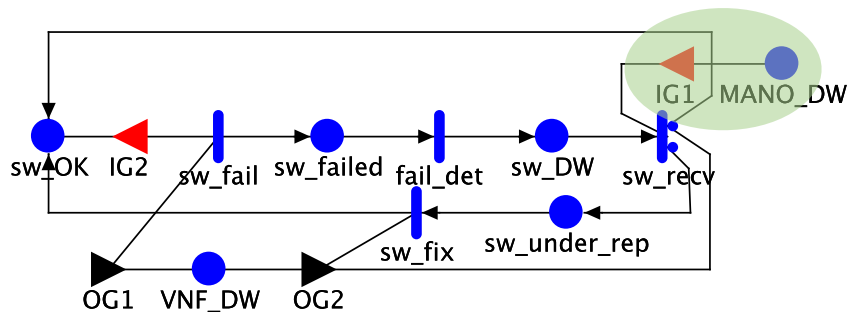

HP

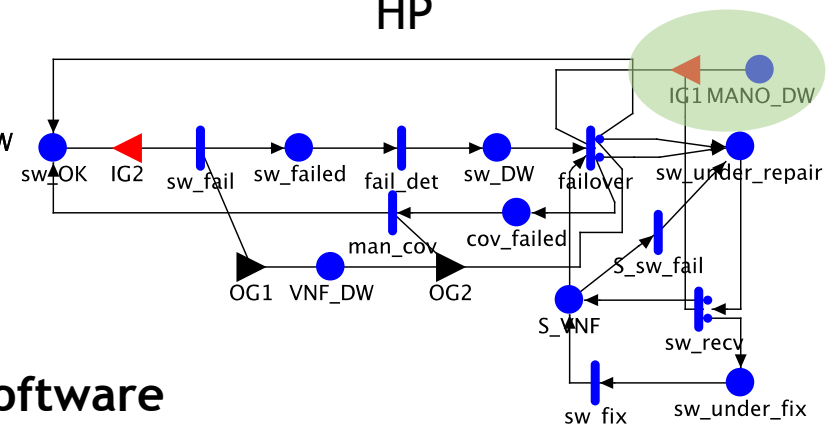

VNF Software

Component's Models - Parameters

- $K = R = 4$
- failure intensities
(retrieved from previous literature)
- Vary N so that $=\{0, 0.25, 0.5\}$
- C_{fo} , C_{mig} = failover , migrate success prob.
- MANO adopts only HP modes

Intensity	Time	Description
$1/\lambda_{hw} = 6.5$	months	mean time to next hardware failure
$1/\mu_{hw} = 1$	hour	mean time to hardware repair
$1/\mu_{fo} = 5$	secs	mean time to VM failover
$1/\mu_{det} = 5$	secs	mean time to failure detection
$C_{fo} = 0.95$		VM failover coverage factor
$1/\mu_{mig} = 1$	minute	mean time to VM migrate
$C_{mig} = 0.95$		VM migrate coverage factor
$1/\lambda_{vmm} = 4$	months	mean time to next VMM failure
$1/\mu_{vmm} = 1$	hour	mean time to VMM fix
$1/\mu_{vmm_{res}} = 30$	secs	mean time to VMM reset
$1/\lambda_{vm} = 2$	months	mean time to next VM failure
$1/\mu_{vm} = 1$	hour	mean time to hard VM fix
$1/\mu_{vm_{res}} = 30$	secs	mean time to VM reset
$1/\lambda_{sw} = 2$	weeks	mean time to next VNF software failure
$1/\mu_{sw} = 1$	hour	mean time to VNF software fix
$1/\mu_{sw_{res}} = 15$	secs	mean time to VNF software restart
$C_{res} = 0.8$		restart coverage factor
$1/\mu_{\Delta} = 30$	minutes	mean time to summon an operator
$1/\lambda_{Msw} = 1$	month	mean time to next MANO software failure
$1/\mu_{Msw} = 1$	hour	mean time to MANO software fix
$1/\mu_{MSW_{res}} = 15$	secs	mean time to MANO software restart
$1/\lambda_{OS} = 1$	month	mean time to next OS failure
$1/\mu_{OS} = 1$	hour	mean time to OS fix
$1/\mu_{OS_{res}} = 1$	minute	mean time to OS reboot
$1/\mu_{cov} = 30$	minutes	mean time to manual coverage
$O = 3$		# VNFs composing the SFC

Numerical Evaluation - Sensitivity Analysis

VNF redundancy configurations and Coverage factor

γ	M	Cold Protection		Hot Protection	
		$C_{mig} = 0.8$	$C_{mig} = 0.99$	$C_{fo} = 0.8$	$C_{fo} = 0.99$
0	1	99.25%	99.30%	99.59%	99.96%
	2	99.26%	99.31%	99.60%	99.98%
	3	99.27%	99.45%	99.61%	99.99%
0.25	1	99.9964%	99.9970%	99.9981%	99.99971%
	2	99.9967%	99.9976%	99.9992%	99.99992%
	3	99.9968%	99.9985%	99.9994%	99.99997%

$\gamma_M = 0.25$

Numerical Evaluation - Sensitivity Analysis

VNF redundancy configurations and Coverage factor

γ	M	Cold Protection		Hot Protection	
		$C_{mig} = 0.8$	$C_{mig} = 0.99$	$C_{fo} = 0.8$	$C_{fo} = 0.99$
0	1	99.25%	99.30%	99.59%	99.96%
	2	99.26%	99.31%	99.60%	99.98%
	3	99.27%	99.45%	99.61%	99.99%
0.25	1	99.9964%	99.9970%	99.9981%	99.99971%
	2	99.9967%	99.9976%	99.9992%	99.99992%
	3	99.9968%	99.9985%	99.9994%	99.99997%

$\gamma_M = 0.25$

Increasing M => negligible availability increase irrespective of the availability mode.

Numerical Evaluation - Sensitivity Analysis

VNF redundancy configurations and Coverage factor

γ	M	Cold Protection		Hot Protection	
		$C_{mig} = 0.8$	$C_{mig} = 0.99$	$C_{fo} = 0.8$	$C_{fo} = 0.99$
0	1	99.25%	99.30%	99.59%	99.96%
	2	99.26%	99.31%	99.60%	99.98%
	3	99.27%	99.45%	99.61%	99.99%
0.25	1	99.9964%	99.9970%	99.9981%	99.99971%
	2	99.9967%	99.9976%	99.9992%	99.99992%
	3	99.9968%	99.9985%	99.9994%	99.99997%

$\gamma_M = 0.25$

Increasing M => negligible availability increase irrespective of the availability mode.

Numerical Evaluation - Sensitivity Analysis

VNF redundancy configurations and Coverage factor

γ	M	Cold Protection		Hot Protection	
		$C_{mig} = 0.8$	$C_{mig} = 0.99$	$C_{fo} = 0.8$	$C_{fo} = 0.99$
0	1	99.25%	99.30%	99.59%	99.96%
	2	99.26%	99.31%	99.60%	99.98%
	3	99.27%	99.45%	99.61%	99.99%
0.25	1	99.9964%	99.9970%	99.9981%	99.99971%
	2	99.9967%	99.9976%	99.9992%	99.99992%
	3	99.9968%	99.9985%	99.9994%	99.99997%

$\gamma_M = 0.25$

Increasing M => negligible availability increase irrespective of the availability mode.

Increasing produces up to three orders of magnitude increase

Numerical Evaluation - Sensitivity Analysis

VNF redundancy configurations and Coverage factor

γ	M	Cold Protection		Hot Protection	
		$C_{mig} = 0.8$	$C_{mig} = 0.99$	$C_{fo} = 0.8$	$C_{fo} = 0.99$
0	1	99.25%	99.30%	99.59%	99.96%
	2	99.26%	99.31%	99.60%	99.98%
	3	99.27%	99.45%	99.61%	99.99%
0.25	1	99.9964%	99.9970%	99.9981%	99.99971%
	2	99.9967%	99.9976%	99.9992%	99.99992%
	3	99.9968%	99.9985%	99.9994%	99.99997%

$$\gamma_M = 0.25$$

Increasing M => negligible availability increase irrespective of the availability mode.

Increasing produces up to three orders of magnitude increase

Numerical Evaluation - Sensitivity Analysis

VNF redundancy configurations and Coverage factor

γ	M	Cold Protection		Hot Protection	
		$C_{mig} = 0.8$	$C_{mig} = 0.99$	$C_{fo} = 0.8$	$C_{fo} = 0.99$
0	1	99.25%	99.30%	99.59%	99.96%
	2	99.26%	99.31%	99.60%	99.98%
	3	99.27%	99.45%	99.61%	99.99%
0.25	1	99.9964%	99.9970%	99.9981%	99.99971%
	2	99.9967%	99.9976%	99.9992%	99.99992%
	3	99.9968%	99.9985%	99.9994%	99.99997%

$\gamma_M = 0.25$

Increasing M => negligible availability increase irrespective of the availability mode.

Increasing produces up to three orders of magnitude increase

HP mode is more sensitive to coverage factor variations compared to the CP mode.

Numerical Evaluation - Sensitivity Analysis

Effects of VNF cluster overprovisioning for different failure intensities.

Failure Intensities	γ	Standard Availability	Cold Protection	Hot Protection
λ_{ref}	0	98.9%	99.30%	99.88%
	0.25	99.994%	99.997%	99.9997%
	0.5	99.999941%	99.99997%	99.999993%
$10 \cdot \lambda_{ref}$	0	90.35%	93.18%	97.59%
	0.25	99.47%	99.71%	99.80%
	0.5	99.91%	99.98%	99.99%

M=1 and

Numerical Evaluation - Sensitivity Analysis

Effects of VNF cluster overprovisioning for different failure intensities.

Failure Intensities	γ	Standard Availability	Cold Protection	Hot Protection
λ_{ref}	0	98.9%	99.30%	99.88%
	0.25	99.994%	99.997%	99.9997%
	0.5	99.999941%	99.99997%	99.999993%
$10 \cdot \lambda_{ref}$	0	90.35%	93.18%	97.59%
	0.25	99.47%	99.71%	99.80%
	0.5	99.91%	99.98%	99.99%

M=1 and

With reference parameters, only the HP mode achieves 5-nines when $\gamma=0.25$

Numerical Evaluation - Sensitivity Analysis

Effects of VNF cluster overprovisioning for different failure intensities.

Failure Intensities	γ	Standard Availability	Cold Protection	Hot Protection
λ_{ref}	0	98.9%	99.30%	99.88%
	0.25	99.994%	99.997%	99.9997%
	0.5	99.999941%	99.99997%	99.999993%
$10 \cdot \lambda_{ref}$	0	90.35%	93.18%	97.59%
	0.25	99.47%	99.71%	99.80%
	0.5	99.91%	99.98%	99.99%

M=1 and

With reference parameters, only the HP mode achieves 5-nines when $\gamma=0.25$

For higher failure intensities, none of the modes reaches 5 nines availability

Numerical Evaluation - Sensitivity Analysis

Effects of MANO cluster overprovisioning.

γ_M	Standard Availability	Cold Protection	Hot Protection
0	99.97%	99.97%	99.98%
0.25	99.99425%	99.9970%	99.999731%
0.5	99.99428%	99.9971%	99.999732%

M=1 and

- The availability is augmented by one nine when the provisioning ratio is increased from 0 to 0.25 but remains almost unchanged when the ratio becomes higher.
- Therefore, a high overprovisioning does not bring benefits on the service availability.

Conclusions

- Proposed a flexible availability model based on SAN composition
- Investigated three different protection mechanisms
- Service availability is sensitive to a correct dimensioning of the VNF and MANO clusters.
- A high MANO overprovisioning does not bring a substantial advantage.
- In HP mode, the failover robustness can be exploited to achieve up to one order of magnitude availability boost.

Future work

- Evaluate MANO impact when it adopts different Availability Modes
- Virtualized and separated MANO model (NFVO, VNFM, and VIM)
- VNF failure correlation (commonalities)

Thank You for Your attention !

The work for this paper was performed in the context of the EU FP7 Marie Curie Actions project Grant Agreement No. 607584 (the Cleansky project).

<http://www.cleansky-itn.org/>

